

## ENGLISH

### **Tmd/smd frequency inverter: Remote Keypad**

The Remote Keypad option ESMD01KP can only be used with **Tmd/smd** models that have an "L" as the eighth digit in the model number (ex. ESMD371L4TXA).



#### **WARNING!**

Improper wiring may result in damage to the Remote Keypad. Keep the remote keypad cable away from power wiring. Use Belden 9842, Carol C4842, or equivalent wire only.

The specified cables consist of two twisted pairs. Make sure one twisted pair is used for power and the other is used for serial communications. Do not mix connections between twisted pairs.

## DEUTSCH

### **Frequenzumrichter Tmd/smd: Externes Keypad**

Das externe Keypad ESMD01KP ist nur bei Frequenzumrichtern Tmd/smd einsetzbar, die ein "L" an der achten Stelle der Typenbezeichnung aufweisen (z.B. ESMD371L4TXA).



#### **ACHTUNG!**

Falsche Verdrahtung kann das externe Keypad beschädigen. Leitung zum externen Keypad nicht in der Nähe der Netzleitung oder Motorleitung verlegen. Benutzen Sie nur Belden 9842, Carol C4842 oder äquivalente Kabel.

Die spezifizierten Kabel bestehen aus zwei verdrehten Adern-Paaren. Stellen Sie sicher, dass ein Paar für die Stromversorgung, das andere für die serielle Kommunikation benutzt wird. Anschlüsse nicht vertauschen.

## FRANÇAIS

### **Convertisseur de fréquence Tmd/smd: Clavier Déporté**

Le clavier déporté ESMD01KP peut seulement être utilisé avec les modèles Tmd/smd ayants un "L" en huitième position de leur référence (ex. ESMD 371L4TXA).



#### **ATTENTION !**

Un mauvais câblage peut engendrer un endommagement du clavier déporté. Gardez éloigner les câbles du clavier déporté des raccordements de puissance. Utilisez seulement Belden 9842, Carol C4842 ou les câbles équivalents.

Les câbles spéciaux consistent de deux paires blindé torsadées. Assurez vous qu'une paire torsadée soit utilisée pour l'alimentation du clavier et que l'autre soit utilisée pour la communication série. Ne mélangez pas les raccordements entre les paires.

## ITALIANO

### **Convertitore di frequenza Tmd/smd: tastiera remota**

La tastiera remota opzionale ESMD01KP può essere applicata solo ai modelli di **Tmd/smd** con la lettera "L" alla posizione 8 della sigla (es. ESMD371L4TXA).



#### **ATTENZIONE!**

Il cablaggio errato del tastierino remota può provocare danni all'apparecchiatura. Mantenere i cavi del tastierino remota lontani da quelli di potenza. Usare solo i cavi Belden 9842, Carol C4842 o equivalenti.

I cavi sono formati da due doppini schermati. Assicurarsi che un doppino sia usato per l'alimentazione e l'altro per la comunicazione seriale. Non scambiare le connessioni dei due doppini intrecciati.

## ESPAÑOL

### **Convertidor de frecuencia Tmd/smd: Keypad Remoto**

La opción de keypad remoto ESMD01KP sólo se puede usar con los modelos **Tmd/smd** que tienen una "L" en el número de modelo de ocho dígitos (ej. ESMD371L4TXA).



#### **¡AVISO!**

El cableado incorrecto puede dañar el keypad remoto. Mantener el cable del keypad remoto separado del cableado de potencia. Usar cable Belden 9842, Carol C4842 ó equivalente.

Los cables especificados consisten en dos pares trenzados. Asegúrese de que un par es usado para la alimentación y el otro para la comunicación serie. No mezclar conexiones entre los pares trenzados.

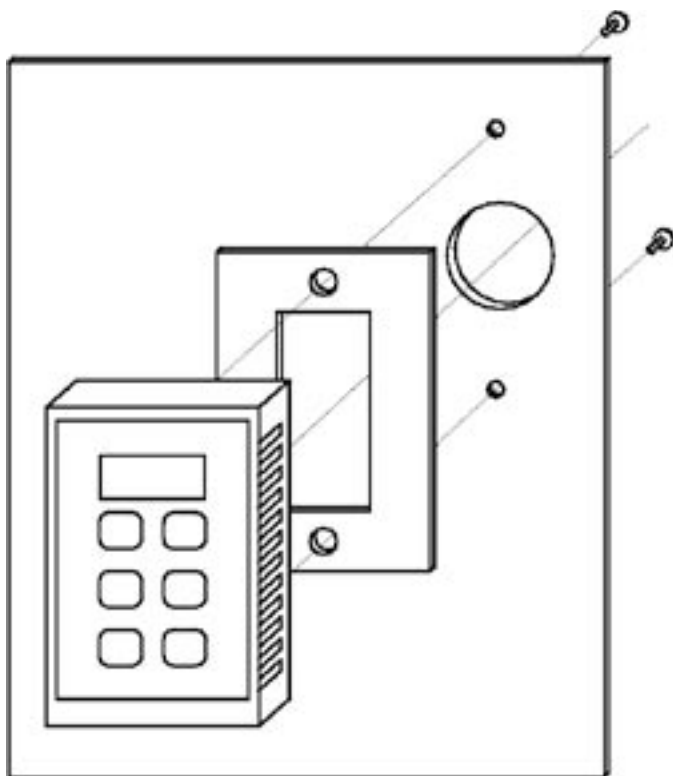
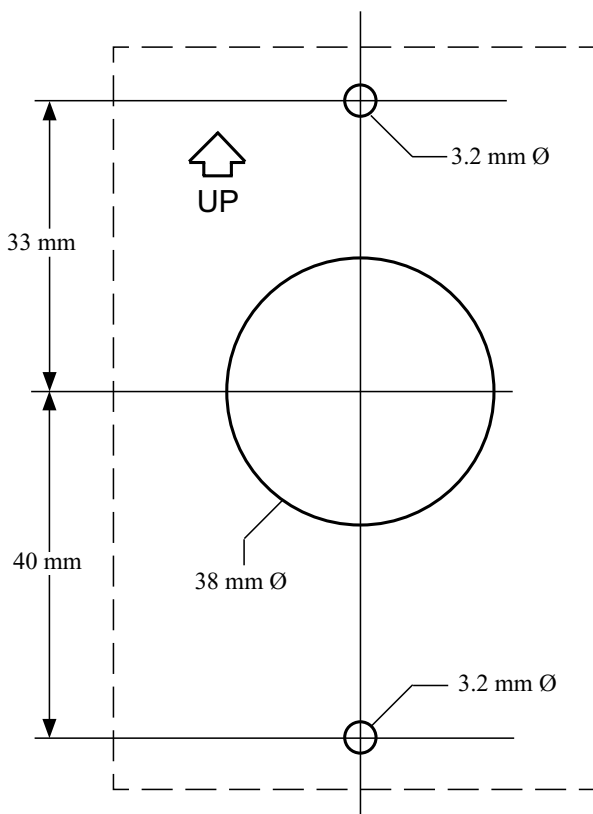

smdrk03

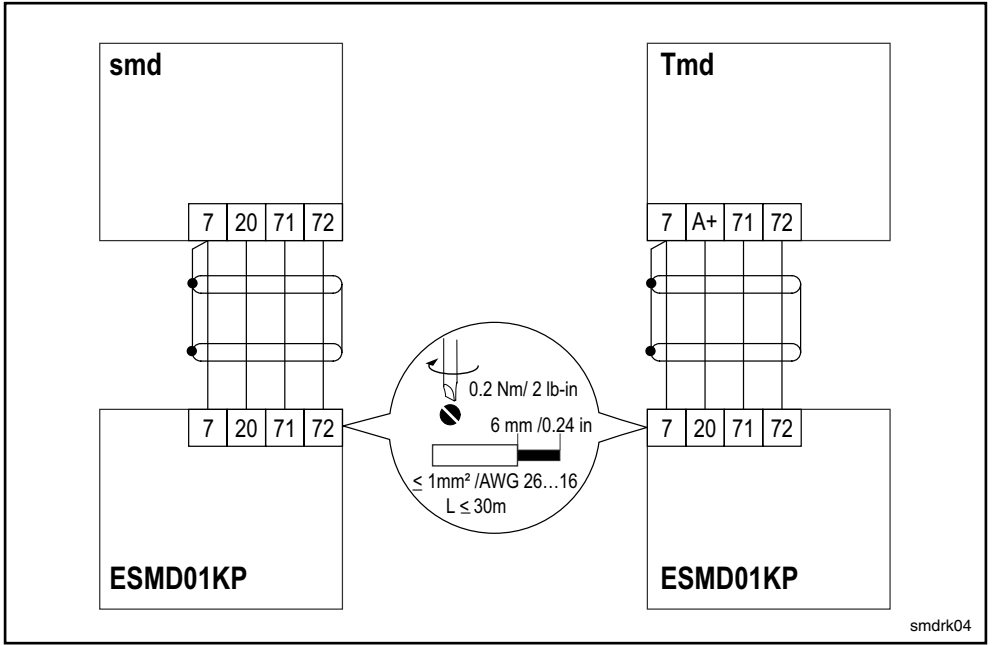

**Parameter Setting Parametrierung Paramétrage  
Configurazione parametri Ajuste de parámetros**

	No.	Name	Required Setting
<b>ENGLISH</b>	001	Setpoint and control source	4, 5, 6, or 7 Refer to inverter instructions to select desired operation
<b>DEUTSCH</b>	Nr.	Bezeichnung	Erforderliche Einstellungen
	001	Sollwertquelle	4, 5, 6, oder 7 Ausführliche Beschreibung der Auswahlfziffern: siehe Frequenzumrichter Betriebsanleitung
<b>FRANÇAIS</b>	N°	Désignation	Réglage requis
	001	Origine de la consigne	4, 5, 6, ou 7 Se reporter aux instructions du convertisseur pour choisir le fonctionnement désiré
<b>ITALIANO</b>	No.	Nome	Impostazioni Richiesta
	001	Sorgente setpoint e comando	4, 5, 6, o 7 Fare riferimento alle istruzioni dell'inverter convertitore per selezionare la modalità desiderata
<b>ESPAÑOL</b>	N°	Nombre	Configuración Requerido
	001	Fuente de consigna y control	4, 5, 6, ó 7 Consultar el manual del convertidor para seleccionar la operación deseada



Same as **Enter** on front of inverter.



Selects rotation direction. Press **R/F** to select the desired direction (see display examples), and then press **M** within four seconds to confirm the change. **R/F** is only active if C01 is set to 6 or 7.



Same as **▲** and **▼** on front of inverter.



Forward (CW) Reverse (CCW)



Press **RUN** to Start the inverter. **RUN** is only active if C01 is set to 6 or 7.



Press **STOP** to Stop the inverter. **STOP** is active whenever the remote keypad is operational, even if the remote keypad is only used for programming.



Gleiche Funktion wie **Enter** auf der Frontseite des Frequenzumrichters.



Auswahl Drehrichtung. **R/F** drücken, um gewünschte Drehrichtung zu wählen (das Display zeigt die Drehrichtung). Dann innerhalb von vier Sekunden **M** drücken, um die Drehrichtungsänderung zu bestätigen.



Gleiche Funktion wie **▲** und **▼** auf der Frontseite des Frequenzumrichters.



Rechtslauf Linkslauf



**RUN** drücken, um den Antrieb zu starten. **RUN** ist nur aktiv, wenn C01 = 6 oder C01 = 7.



**STOP** drücken, um den Antrieb zu stoppen. **STOP** ist immer aktiv, wenn das externe Keypad betriebsbereit ist, auch während des Parametrierens.



Equivalent à **Enter** sur la face avant du convertisseur.



Choix du sens de rotation. Appuyez sur **R/F** pour choisir le sens voulu (voir les exemples d'affichage), et appuyez sur **M** pendant 4 secondes pour confirmer le changement. **R/F** est seulement actif si C01 est réglé à 6 ou à 7.



Identique à **▲** et **▼** sur la face avant du convertisseur.



Horaire Anti-horaire



Appuyez sur **RUN** pour démarrer l'entraînement. **RUN** est seulement actif si C01 est réglé à 6 ou à 7.



Appuyez sur **STOP** pour arrêter l'entraînement. **STOP** est actif uniquement quand le clavier déporté est opérationnel, même si le clavier déporté est seulement utilisé pour le paramétrage.



Equivale al tasto Enter sul frontale dell'inverter convertitore.



Selezionare senso di rotazione. Premere R/F per scegliere la direzione desiderata (vedere gli esempi di visualizzazione), e successivamente premere **M** entro quattro secondi per confermare la modifica. **R/F** è attivo solamente con C01 impostato a 6 o 7.



Equivale **▲** e **▼** sul frontale dell'inverter convertitore.

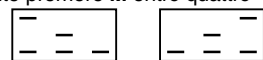

Oraio Antiorario



Premere **RUN** per avviare l'inverter. **RUN** è attivo solamente con C01 impostato a 6 o 7.



Premere **STOP** per fermare l'inverter. **STOP** è attivo tutte le volte che il tastierino remotabile è in funzione, anche se il tastierino remotabile è usato solo per la parametrizzazione.



Igual al **Enter** en el frontal del convertidor.



Selección de la dirección de rotación. Pulsar **R/F** para seleccionar la dirección deseada (ver ejemplos del display), y presionar **M** durante 4 seg. para confirmar el cambio. **R/F** está sólo activo si C01 está ajustado a 6 ó 7.



Igual a **▲** y **▼** en frente del convertidor.



Derecha Izquierda



Pulsar **RUN** para arrancar el convertidor. **RUN** está sólo activo si C01 está ajustado a 6 ó 7.



Pulsar **STOP** para parar el convertidor. **STOP** está activo siempre que el keypad remoto esté operativo, incluso si el keypad remoto se usa sólo para programación.